

# 'TRANSETTE'

MODEL: 7 T.W.

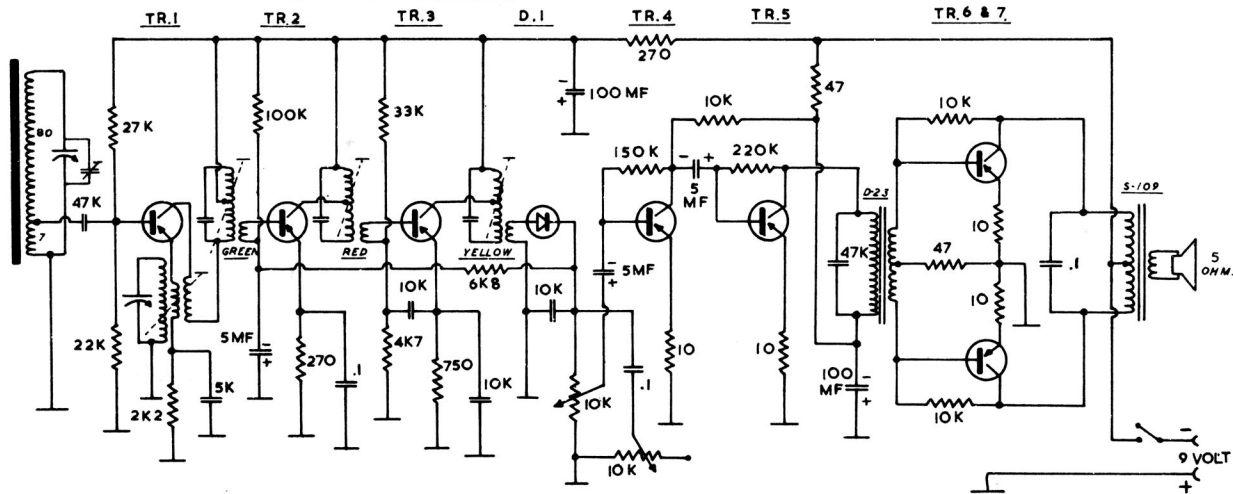

### INTERCHANGEABILITY CHART:

TR.1	TR.2	TR.3	D.1	TR.4	TR.5	TR.6,7
2SA30	2SA31	2SA31	1NA4	2SB32	2SB33	2SB33
2N412	2N410	2N410	ANY	2N408	2N408	2N408
OC44	OC45	OC45	OA70	OC70	OC71	OC72

1F-475 KC.

STANDING CURRENT:  
10...12 MA

### VOLTAGE CHART:

TAKEN WITH V.T.V.M.

	TR.1	TR.2	TR.3	TR.4	TR.5	TR.6,7
BASE	-3.3	-.5	-.9	-.14	-.2	-.18
EMITTER	-3.2	-.3	-.7	-.01	-.04	-.02
COLLECT.	-7.8	-7.8	-7.8	-.15	-7.5	-9.0

TAKEN BETWEEN BATTERY POS. & TEST POINT.

**BELL RADIO-TELEVISION CORP. LTD.**